



## Application note for the Integrated Cooling System

The integrated cooling system (ICS) is designed to dissipate up to 140W of heat while maintaining an average base temperature of 5C above ambient. The ICS uses a convective cooling fan to dissipate heat generated by the attached device. Higher wattages of heat can be dissipated with an increase in average base temperature.



The integrated cooling system (ICS) if purchased without the SemiNex multi-chip module (MCM) is shipped as a stand alone entity with pre-tapped holes to accommodate the MCM. The ICS is comprised of a heatsink and convective cooling fan fully assembled. The dimensioned drawing appears in figure 1.

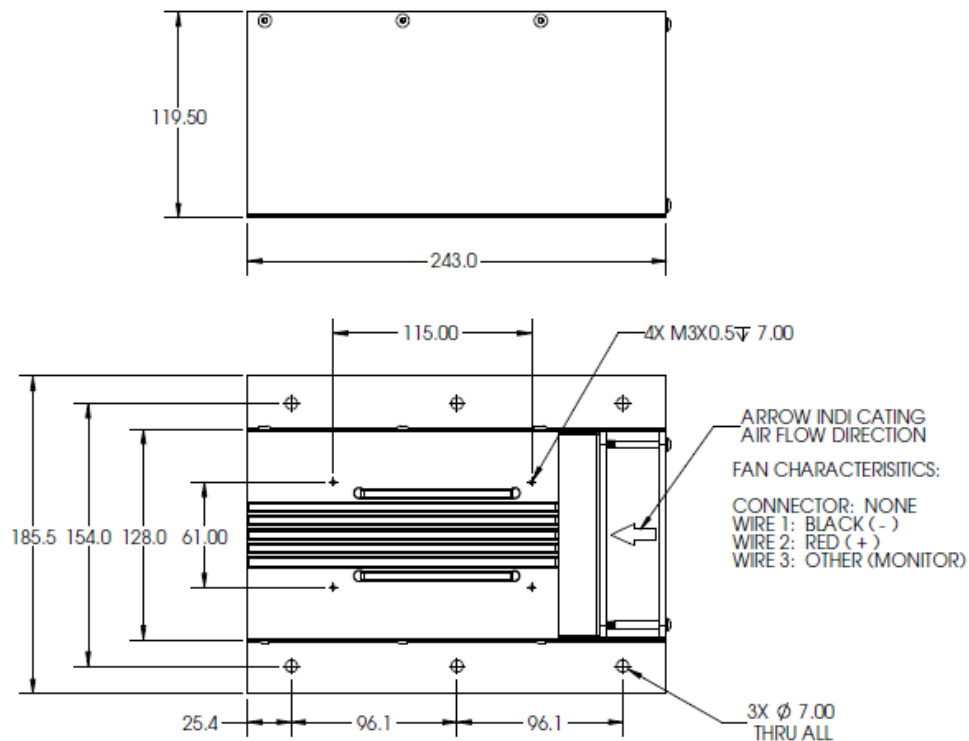

Figure 1. ICS Dimensions

All statements, technical information and recommendation related to the product herein are based upon information believed to be reliable or accurate. However, the accuracy or completeness hereof is not guaranteed, and no responsibility is assumed for any inaccuracies. The user assumes all risks and liability whatsoever in connection with the use of a product or its application. SemiNex Incorporated reserves the right to change at any time without notice, the design, specification, deduction, fit or form of its described herein, including withdrawal at any time of a product offered for sale herein. SemiNex Incorporated makes no representations that the products herein are free from any intellectual property claims of others. Please contact SemiNex Incorporated for more information. © 2009 Copyright SemiNex Incorporated. All rights reserved.

**SemiNex Corporation**  
 153 Andover Street  
 Suite 201  
 Danvers, MA 01923  
 Phone: 978-326-7700  
 Email: [info@seminex.com](mailto:info@seminex.com)  
 Web site: [www.seminex.com](http://www.seminex.com)

## **MCM Attachment**

Attaching the MCM to the ICS requires 4, M3 screws. For long term use and highly efficient thermal transfer between the MCM and ICS, a layer of thermal grease should be used. Recommended thermal greases are ShinEtsu Micro Si Product X23-7762, ShinEtsu Micro Si Product G751 or Artic Silver 5. For short term operation, the use of thermal grease can be avoided, but the temperature rise will be larger than with the grease which will result in a decrease in optical power.

### *MCM Attachment without thermal grease*

Wipe the bottom of the MCM and top of the ICS with a clean cloth to remove any particles. Place the MCM on the ICS aligning the holes in the four corners of the MCM with the holes in the ICS. Place one M3 screw in each hole and secure. Tighten the bolts in sequence across the module from corner to corner using a torque wrench. Use caution to prevent over tightening. Do not exceed 5 in-pounds.

### *MCM Attachment with Thermal Grease*

Wipe the bottom of the MCM and top of the ICS with a clean cloth to remove any particles. A small volume of thermal grease (between 50um and 75um thick) is to be applied to the top of the ICS using a window screening process. Tools required are a roller, squeegee or straight edge, masking tape, thermal grease and cleaning towels.

On the top surface of the ICS, create an outline of the MCM base using the masking tape. Apply a small amount of grease to the area. Spread the grease as evenly as possible using the roller or squeegee. Remove the tape and apply the module, base down, with a slight twisting motion to spread the grease. Align the bolt holes of the MCM to the bolt holes in the ICS and secure with M3 screws. Tighten the bolts in sequence across the module from corner to corner using a torque wrench. Use caution to prevent over tightening. Do not exceed 5 in-pounds. Remove any excess grease using the towels.

## **Air Flow Discharge**

The ICS is designed such that air is pulled through the fan and exhausted through the heatsink. If the ICS is to be installed in an enclosure, two open areas; one for the air intake and one for the discharge, should be used and are to be no smaller than 120mm x 120mm in area each.

## **Fan Specifications**

The fan is voltage driven and requires 12V and 0.6A for proper operation. Three wires protrude from the fan. The red wire is positive; black is negative and third is a tachometer wire. Connect the positive lead from the power supply to the red wire and the negative lead from the power supply to the black wire. If desired, the fan rotation can be monitored by connecting the tachometer wire to a pull-up resistor connected to a voltage supply. The observed pulse train will be proportional to the fan speed.